

Pneumatic Damper Actuators General Instructions

APPLICATION

Proportional pneumatic actuator with 8 in.² (52 cm²) effective area used to control dampers, mixing boxes, air valves, etc., in heating, ventilating and air conditioning systems, MK2-31X1 used for high temperatures.

SPECIFICATIONS

Construction:

Housing, Die cast aluminum.

Diaphragm, Beaded molded neoprene. *MK2-31X1 only* - Beaded molded silicone.

Stroke: See Table 2.

Start Point: Adjustable on most models ± 1 psi, see Table 2.

Spring: Retracts actuator shaft on loss of air pressure.

Maximum Air Pressure: 30 psig (207 kPa).

Ambient Temperature Limits:

Shipping, -40 to 160°F (-40 to 71°C).

Operating, -20 to 160°F (-29 to 71°C).

MK2-31X1 only,

Shipping, -40 to 250°F (-40 to 121°C).

Operating, -20 to 250°F (-29 to 121°C), for 30 minute exposure 450°F (232°C).

Air Connections: 1/8" FNPT.

Mounting: In any position. Mounting bracket (except MK-3300 Series end mounting) and connector for 5/16" (8 mm) diameter push rod included with actuator.

Dimensions: 12" high x 5-7/8" wide x 5-1/2" deep (305 mm x 143 mm x 140 mm)

ACCESSORIES

AK-42309-500	Positive positioner and linkage, do not use with MK2-3100 series
AM-111	Crank arm for 5/16" diameter damper shaft
AM-112	Crank arm for 3/8" diameter damper shaft
AM-113	Crank arm for 1/2" diameter damper shaft
AM-115	Crank arm for 7/16" diameter damper shaft
AM-122	Linkage connector straight type
AM-123	Damper clip
AM-125	5/16" x 20" damper rod
AM-125-048	5/16" x 48" damper rod
AM-132	Ball joint connector
AM-161-3	Damper linkage kit
AM-301	90° mounting bracket for pivot mounting
AM-530	Crank arm for 1/2" diameter damper shaft holes for 3-1/2" and 4-1/2" stroke
AM-532	Bolt-on frame lug and damper blade clip kit
AM-533	Actuator shaft extension
AM-534	Pivot stud for pivot mounting
AM-535	Clevis for pivot mounting
AM-536	Mounting plates for pivot mounting on ducts or damper frame
AM-545	Rod end connector for 5/16" (10 mm) dia. rods
TOOL-95	Pneumatic calibration tool kit

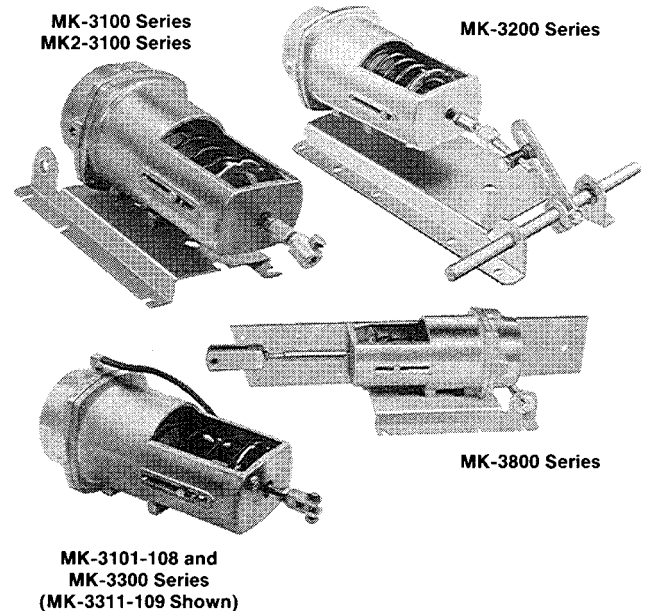

Table-1 Nominal Damper Area For Proportional Control^a

Actuator Part Number	Parallel Blades		Opposed Blades	
	ft ²	m ²	ft ²	m ²
MK-3101 MK-3101-108 MK2-3101 MK4-3101 MK-3111 MK2-3111 MK-3121-109 MK-3121 MK2-3121 MK-3141 MK4-3141 MK-3151 MK-3161 ^b MK-3201 MK-3211 MK-3221 MK-3311-109 MK-3321-102 MK-3801 MK4-3801 MK-3811 MK-3821 MK-3841 MK4-3841	11.6	1.07	15	1.39
MK4-3111 ^c MK4-3811 ^c	23.2	2.15	30	2.79
MK4-3121 ^d MK4-3821 ^d	34.8	3.23	45	4.18

^a For two-position control use proportional rating of the same actuator with positive positioner. Damper ratings are nominal and based on standard (not low leakage) dampers at 1" (25.4 mm) W.C. static pressure and 2000 fpm (10 m/s) velocity.

^b Requires 20 psi be available to the actuator.

^c Requires minimum 15 psi be available to the actuator.

^d Proportional control with positioner (8-13 spring, 20 psi supply).

Table-2 Specifications.

Part Number	Nominal Operating Range		Starting Pressure		Nominal Stroke ^a	Maximum Force ^b								Nominal Torque ^c Proportional Control ^b					
						Return Stroke		Power Stroke						15 psi (103 kPa) Supply Dual Press. System			15 psi (103 kPa) Supply Single Press. System		
	Based on 1.5 psi (10 kPa) Pressure to Actuator		15 psi (103 kPa) Supply Dual Press. System			15 psi (103 kPa) Supply Single Press. System ^d		20 psi (138 kPa) Supply Single or Dual Press. System		15 psi (103 kPa) Supply Dual Press. System			15 psi (103 kPa) Supply Single Press. System			20 psi (138 kPa) Supply Single or Dual Press. System ^d			
	psig	kPa	psig	kPa		in. (mm)	lb.	N	lb.	N	lb.	N	lb.	N	lb-in.	N-m	lb-in.	N-m	lb-in.
MK-3101-108	3-7.2	21-50	3 ± 1	21 ± 7	3 (76) Adjustable 2 to 4 (51 to 102)	12	53	50	226	62	276	102	454	18	2.03	18	2.03	18	2.03
MK-3101 MK2-3101	3-8	21-55	3 ± 1	21 ± 7	3 1/2 (89) Adjustable 2 to 4 (51 to 102)	12	53	44	196	56	249	96	427	21	2.37	21	2.37	21	2.37
MK4-3101^e	3-8	21-55	3 ± 1	21 ± 7		12	53	44	196	56	249	96	427	21	2.37	21	2.37	21	2.37
MK-3111 MK2-3111	5-10	34-69	5 ± 1	3 ± 7		28	125	28	125	40	178	80	356	21	2.37	21	2.37	21	2.37
MK4-3111	5-10	34-69	5 ± 1	34 ± 7		28	125	28	125	40	178	80	356	49	5.54	49	5.54	49	5.54
MK-3121 MK-3121-109 MK2-3121^e	8-13	55-90	8 ± 1	55 ± 7		52	231	4	18	16	71	56	249	7	79	21	2.37	21	2.37
MK4-3121^e	8-13	55-90	8 ± 1	55 ± 7		52	231	4	18	16	71	56	249	7	79	28	3.16	91	10.28
MK-3141 MK4-3141^e	3-13	21-90	3 non-adj	21 non-adj		12	53	4	18	16	71	56	249	7	79	21	2.37	21	2.37
MK-3151	3-6 9-12	21-41 62-83	3-6	21 to 41	2-3/4 (70) Adjustable 2 to 2-3/4 (51 to 70)	12	53	12	53	24	107	64	285	21	2.37	21	2.37	21	2.37
MK-3161	3-6 11-17	21-41 76-117	3-6	21 to 41	12	53	0	0	0	0	24	107	0	0	0	0	21	2.37	
MK-3201	3-8	21-55	3 ± 1	21 ± 7	90° Rotation Typical, Adjustable 1.2 to 4.4 (30 to 111)	12	53	44	196	56	249	96	427	21	2.37	21	2.37	21	2.37
MK-3211	5-10	34-69	5 ± 1	34 ± 7		28	125	28	125	40	178	80	356	21	2.37	21	2.37	21	2.37
MK-3221	8-13	55-90	8 ± 1	55 ± 7		52	231	4	18	16	71	56	249	7	.79	21	2.37	21	2.37
MK-3311-109	5-10	34-69	5 ± 1	34 ± 7	3-1/2 (89) Adjustable 2 to 4 (51 to 102)	28	125	28	125	40	178	80	356	21	2.37	21	2.37	21	2.37
MK-3321-102	8-13	55-90	8 ± 1	55 ± 7		52	231	4	18	16	71	56	249	7	.79	21	2.37	21	2.37
MK-3801 MK4-3801^e	3-8	21-55	3 ± 1	21 ± 7	3-1/2 (89) Adjustable 2 to 4 (51 to 102)	12	53	44	196	56	249	96	427	21	2.37	21	2.37	21	2.37
MK-3811	5-10	34-69	5 ± 1	34 ± 1		28	125	28	125	40	178	80	356	21	2.37	21	2.37	21	2.37
MK4-3811	5-10	34-69	5 ± 1	34 ± 1		28	125	28	125	40	178	80	356	49	5.54	49	5.54	49	5.54
MK-3821	8-3	55-90	8 ± 1	55 ± 1		52	231	4	18	16	71	56	249	7	79	21	2.37	21	2.37
MK4-3821^e	8-13	55-90	8 ± 1	55 ± 1		52	231	4	18	16	71	56	249	7	79	28	3.16	91	10.28
MK-3841 MK4-3841^e	3-13	21-90	3 non-adj	21 non-adj		12	53	4	18	16	71	56	249	7	79	21	2.37	21	2.37

^a Factory setting required for published operating range.

^b Force and torques based on factory set stroke and starting pressure.

^c Nominal torque for actuators without positive positioner is based on 1.5 psi pressure change at the actuator.

^d Adjust pressure reducing valve so that listed pressures are available at the actuator.

^e Factory installed positive positioner (AK-42309-500) start point adjustable 2 to 10 psi with range adjustable 2 to 10 psi.

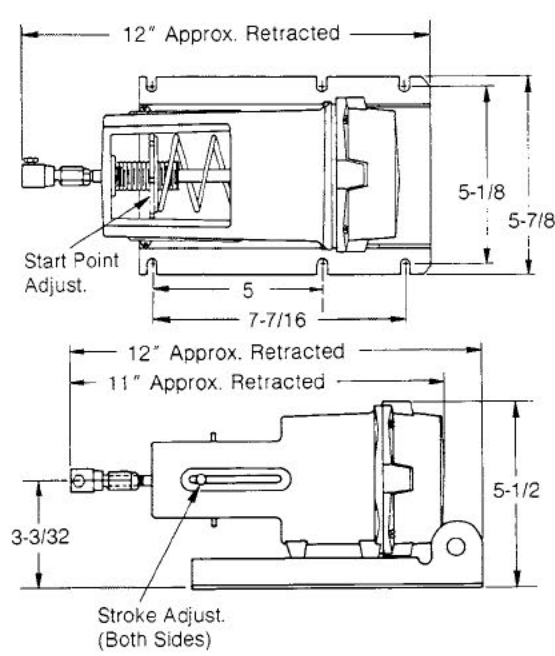

Figure-1 MK-3100 Series Dimensions.¹

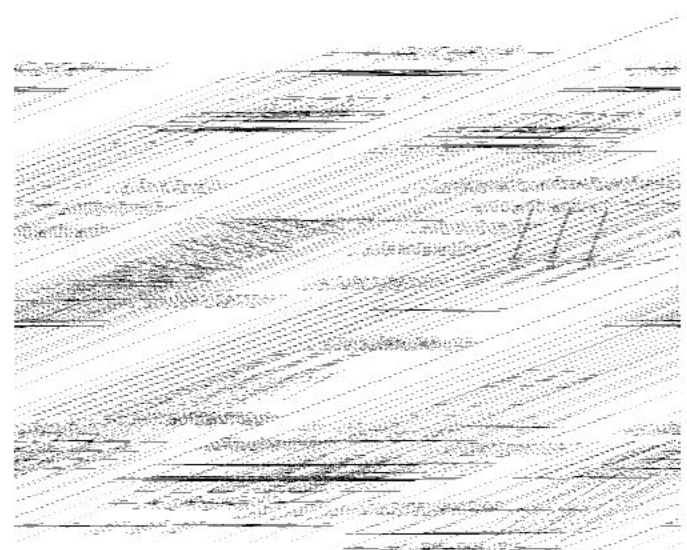
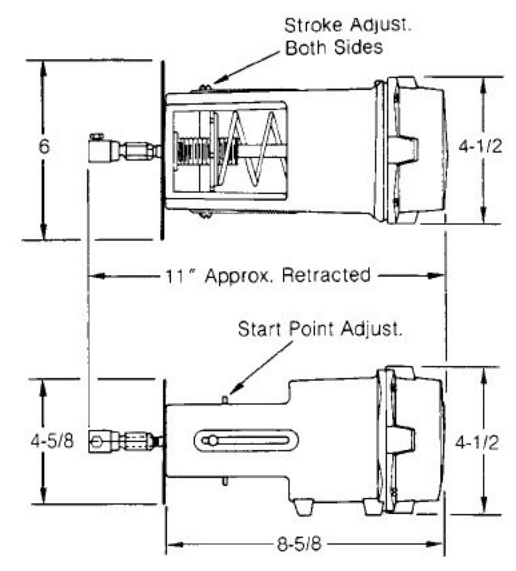

Figure-2 MK-3200 Series Dimensions.



Mounting plate for MK-3101-108 and MK-3300-102 Series Actuators

Figure-3 MK-300 Series Dimensions².

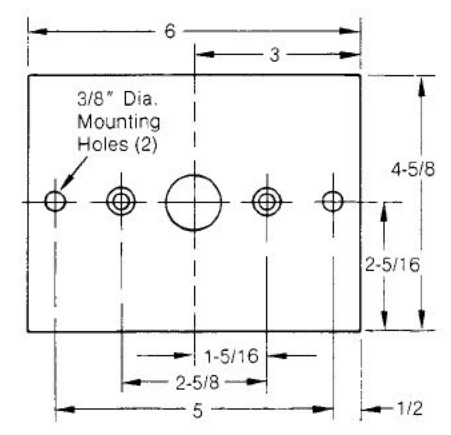

Figure-4 MK-3800 Series Dimensions.

¹ All dimensions shown in the Instruction Sheet are in inches.

² Typical Model shown. Linkage, and air connection details may vary from Model to Model.

MK-3100 Series Typical Mounting

Accessories Required for Mounting Per Figure 5

- 1 — AM-113 Crank arm.
- 1 — AM-122-0-0-2 or AM-132-0-0-2 ball joint.
- 1 — AM-125 link rod 5/16-inch x 20 inches.

To mount proceed as follows. Refer to Figure 5.

1. Measure a minimum of 8 inches from damper shaft in the direction of actuator location.
2. Hold actuator up to duct with actuator shaft approximately 1-1/2 inches above (N.C.) or below (N.O.) damper shaft and mark mounting holes.
3. With drill or punch, pierce holes marked in Step 2.
4. Mount actuator to duct.
5. Attach ball joint to crank arm at approximately 2-1/2 inches from center of shaft hole.
6. Attach crank arm to damper shaft at approximately 45° angle, from vertical, toward actuator with damper in the normal actuator retracted position.
7. Connect actuator ball joint to crank arm ball joint with 5/16-inch diameter rod. Cut off excess rod.
8. Refer to Checkout.

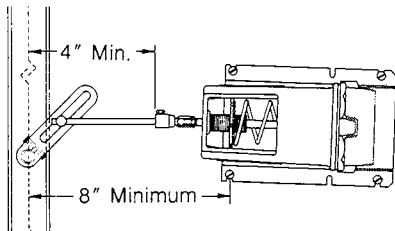

Figure-5 MK-3100 Series Typical Mounting.

MK-3300 Series Typical Mounting

Note: MK-3300 Series Models are designed for Mixing Box applications. Mounting, Linkage, and air connection details vary among Models. See Actuator Selection Sheet F-13795 for more information.

Accessories Required for Mounting Per Figure 8

- 1 — AM-125 link rod 5/16-inch x 20 inches.
- 1 — Connector as required for connection to driven device.

To mount proceed as follows. Refer to Figures 6 and 8.

1. Drill holes in mounting surface as shown in Figure 6.
2. Mount actuator.
3. Connect actuator.
4. Refer to Checkout.

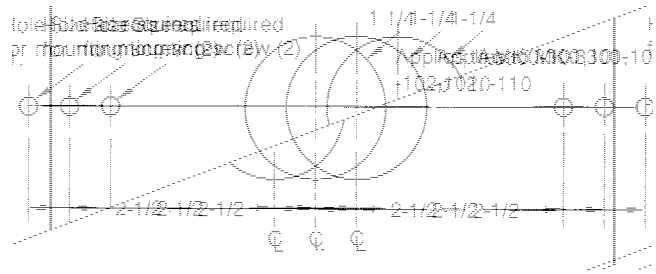

Figure-6

MK-3200 Series Typical Mounting

Accessories Required for Mounting Per Figure 7

- 2 — AM-113 crank arm.
- 2 — AM-122-0-0-2 or AM-132-0-0-2 ball joint.
- 1 — AM-125 link rod 5/16-inch x 20 inches.

To mount proceed as follows. Refer to Figure 7.

1. Locate actuator on a surface perpendicular to the damper shaft, with the actuator rotary shaft approximately in line with the damper shaft.
2. Hold actuator up to duct and mark mounting holes.
3. With drill or punch, pierce holes marked in Step 2.
4. Mount actuator to duct.
5. Attach crank arm to actuator shaft at approximately 45° angle.
6. Attach ball joint to crank at approximately 2-1/2 inches from center of shaft hole.
7. Attach crank arm to damper shaft an approximately 45° angle, from vertical, toward actuator with damper in the normal actuator retracted position.
8. Attach ball joint to crank arm at approximately 2-1/2 inches from center of shaft.
9. Connect actuator ball joint to crank arm ball joint with 5-1/6-inch diameter rod. Cut off excess rod.
10. Refer to Checkout.

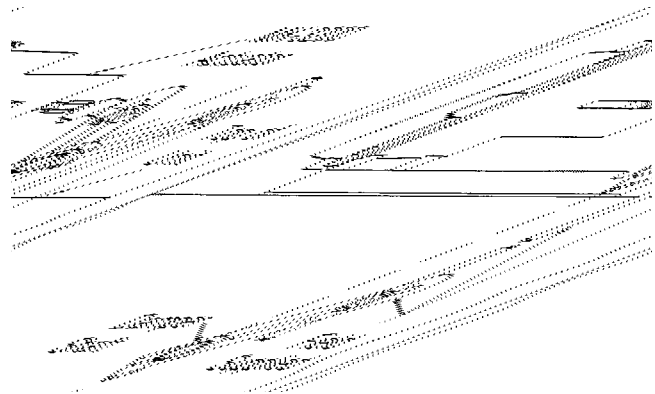

Figure-7 MK-3200 Series Typical Mounting.

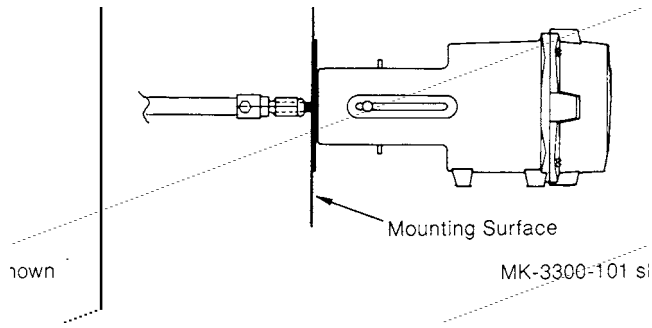

Figure-8 MK-3300 Typical Mounting.

MK-3800 Series Typical Mounting

Accessories Required for Mounting of Actuator Per Figure 9 through 11

1— AM-532 bolt-on frame bracket kit.

Note: Bracket kit includes the frame bracket, leaf connector, and necessary screws or bolts and nuts.

To install the actuator proceed as follows:

1. Prepare the damper by drilling necessary holes, etc. See Figures 11 and 15 for bolt-on bracket.
2. Attach bracket and leaf connector to damper.
3. Attach actuator mounting plate to damper bracket.
4. Install pivot stud to actuator mounting plate.
5. Install actuator to pivot stud and connect clevis to blade connector.

Note: Adjust clevis as needed to align clevis and leaf connector.

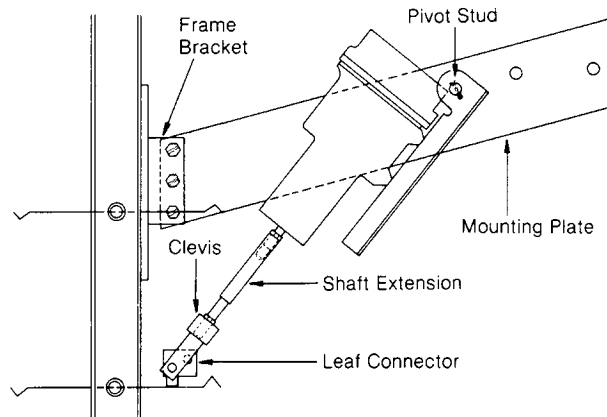

Figure-9 MK-3800 Series Typical Mounting, Normally Open.

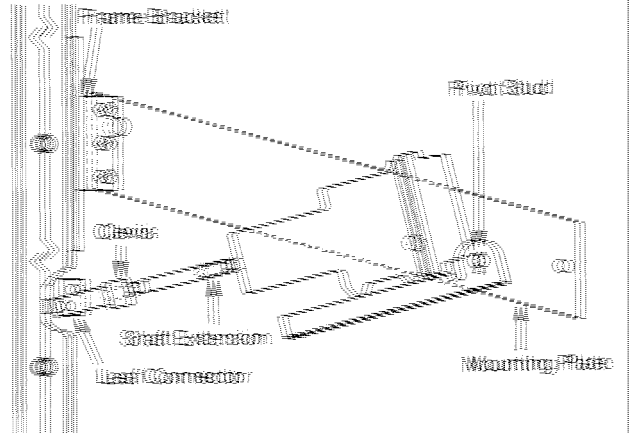

Figure-10 MK-3800 Series Typical Mounting, Normally Closed.

Preparing Damper for Frame Mounting of Actuator

Refer to Figures 11 and 15 for required holes, etc. for AM-532.

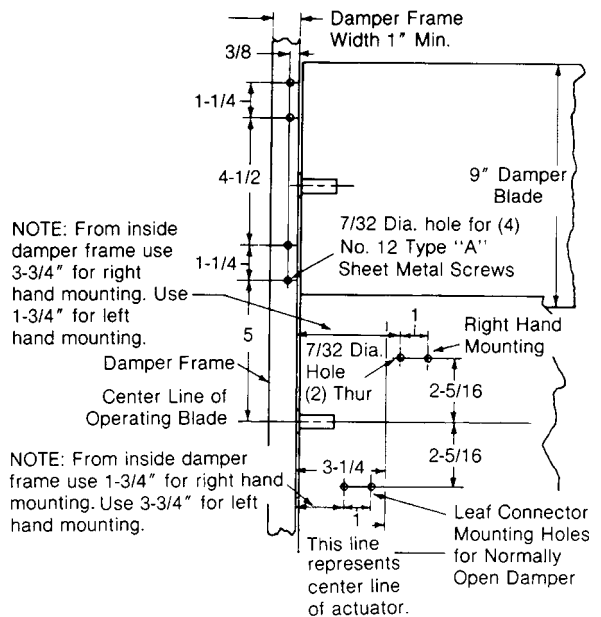

Figure-11 Typical Bolt-On Bracket Mounting.

Accessories Required for Mounting of Actuator Per Figure 12

1 — AM-530 crank arm.

To install proceed as follows:

1. Attach mounting plate to duct or wall with damper shaft protruding through locator hole in mounting plate. If this is not possible, additional shaft extensions may be used to allow locating the actuator farther from the damper shaft. Each extension provides 4 inches of extension to the actuator shaft and may be used in multiples.
2. Install the pivot stud to the mounting plate.
3. Install actuator on pivot stud.
4. Install crank arm on damper shaft at approximately 45° angle from vertical toward actuator.

CHECKOUT

After installation, the actuator should be checked to insure proper damper operation. To check the actuator and linkage, proceed as follows:

1. Check the linkage with the actuator in the retracted position for proper return force. The actuator should be linked so that on a normally closed application, the damper is closed with no more than 1/16-inch compression of the spring. (The actuator shaft would return an additional 1/16-inch if the linkage were disconnected.) For a normally open application, the actuator should be linked with the actuator fully retracted.
2. Apply air pressure to the actuator or pilot port of a positioner and check the linkage as follows. On a normally closed application, the damper should be just full open when the actuator piston reaches the stops in the actuator. On a normally open application, the damper should reach the closed position with no more than 1/16-inch stroke remaining to reach the actuator stops.
3. The above can be obtained through adjustment of the ball joint in the crank arms or by adjustment of the actuator stops. The amount of thread engagement of the actuator ball joint or extension shaft may also be used to assist in proper linking.

Connection of Air Line: On pivot mounting arrangements, Figures 9, 10 and 12, control air lines MUST be terminated at the actuator with at least 6 inches of flexible tubing to allow for pivoting of the actuator. On mounting arrangements, Figures 5, 7 and 8, control air lines may be connected directly with either copper or plastic tubing, as required by application.

Caution: On MK2-31X1 Series, metal connectors and tubing must be used.

Adjustable Starting Pressure: Actuators are available with adjustable starting pressure. To adjust the starting pressure, turn adjusting nut supporting the spring clockwise to increase and counterclockwise to decrease the starting pressure. Each rotation of the adjusting nut changes the starting pressure .04 psi (.28 kPa).

Adjustable Stroke Length: Stroke length is determined by the two stops located on either side of the actuator. Stops are set for 3-1/2-inch stroke. mark this point and measure toward the diaphragm end of the actuator to reduce the stroke or away from the diaphragm end to increase the stroke. Maximum stroke length is 4 inches. By increasing the stroke length, the force available to resist an opposing force is decreased while decreasing the stroke length increases this force.

Diaphragm Replacement: If the actuator diaphragm should leak, it may easily be replaced by removing the four screws holding the top power housing. Make sure that shaft swivel joint is in place on the end of the shaft. Remove the screws and old diaphragm. Roll the new diaphragm inside out and install over the piston making sure the circular bead is facing up. Put the top power housing back in place making sure the bead on the diaphragm is in the housing groove and the screw holes are lined up. Tighten housing screws.

UNITS WITH FACTORY MOUNTED POSITIVE POSITIONERS

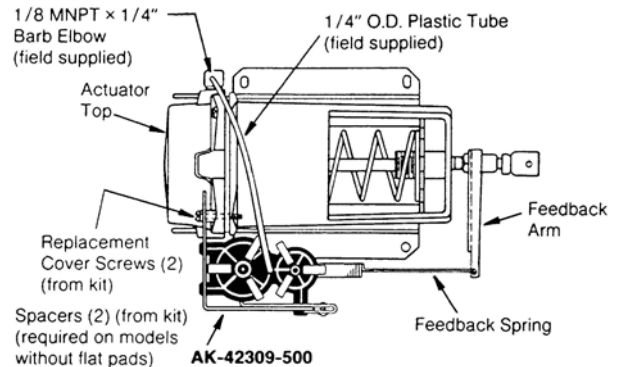

Figure-16 Typical Factory Mounted Positioner.

For Actuators with Positioners:

Note: If actuator is frame pivot mounted, the actuator must be mounted to the left-hand frame. If actuator is mounted external, Figure 12 must be on right-hand side of duct.

Install fittings required in Ports 2 and 3.

ADJUSTMENTS

Refer to Figure 16.

Range Adjustment: Adjustable 2 to 10 psig (14 to 69 kPa). Factory set at 5 psig (34 kPa). Range is the pressure change required to produce full actuator stroke.

If adjustment is required (see Figure 16), with a small screwdriver loosen screw on range slider approximately 1/2 turn.

Move the graduated range slider until desired pressure mark lines up with center of screw and tighten screw.

Start Point: Adjustable 2 to 10 psig (14 to 69 kPa). Start point is the pressure at which the actuator just begins to extend. See Figure 16.

Connect main air supply to Port 3 and a variable air supply to Port 2.

1. Adjust variable air supply on Port 2 to desired start point pressure.
2. Adjust the start point screw with small screwdriver until actuator just starts to extend.
3. Gradually raise pressure on Port 2 until actuator is fully extended, and readjust range slider to obtain desired range if further adjustment is necessary.
4. Remove variable air supply from Port 2 and connect to controller output.

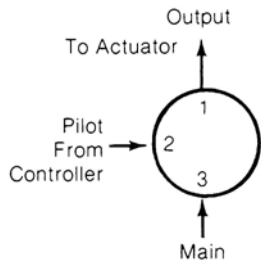

Note: If slave damper actuators are to be controlled, tee into the tubing from Port 1 to the actuators. All dampers must be mechanically interconnected.

Figure-17 Typical Piping Diagram with Factory Mounted Positive Positioner.

On October 1st, 2009, TAC became the Buildings business of its parent company Schneider Electric. This document reflects the visual identity of Schneider Electric, however there remains references to TAC as a corporate brand in the body copy. As each document is updated, the body copy will be changed to reflect appropriate corporate brand changes.

Copyright 2010, Schneider Electric
 All brand names, trademarks and registered trademarks are the property of their respective owners. Information contained within this document is subject to change without notice.